

### Early PLC-30 panel (1 of 2)

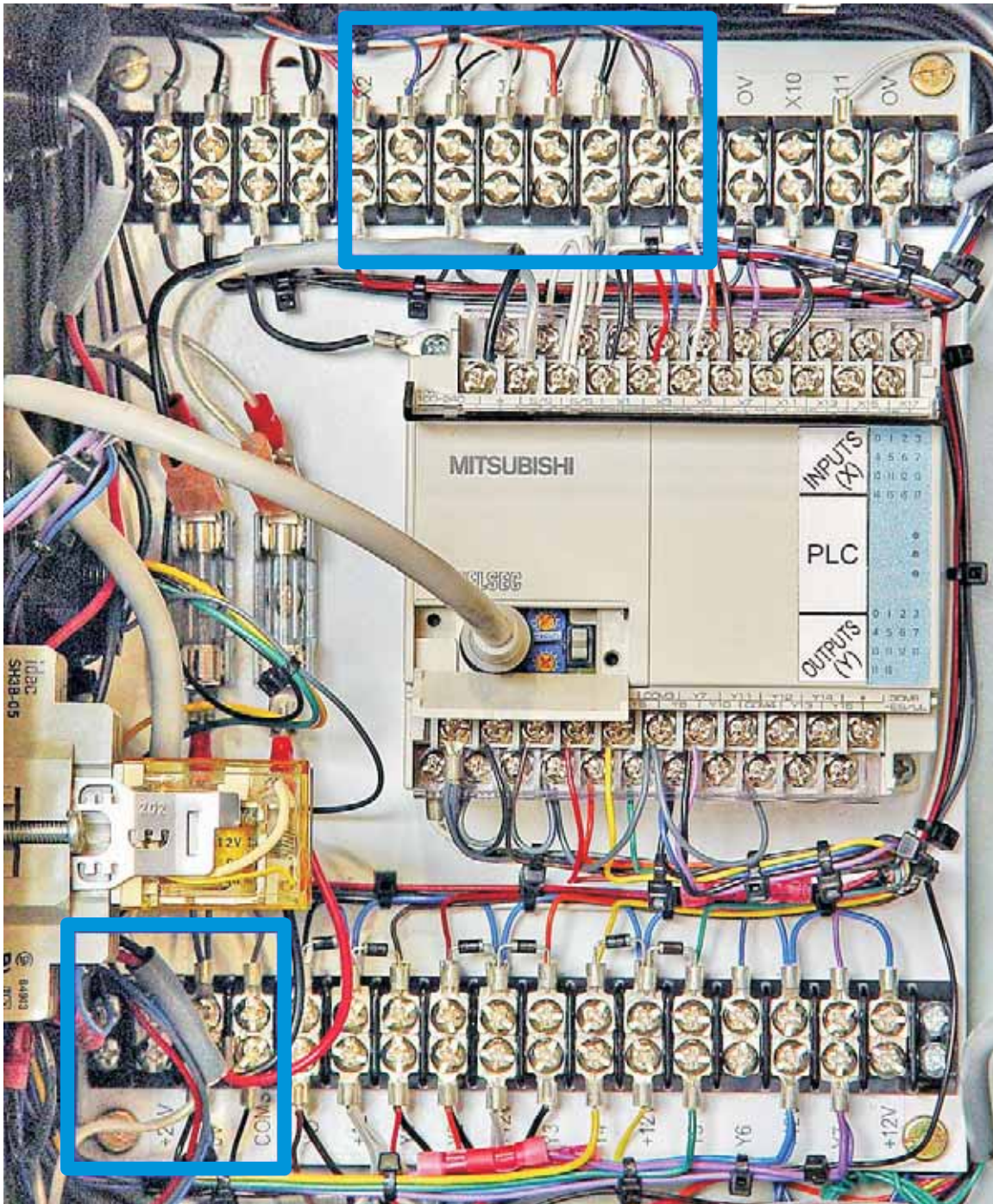

The blue rectangles in the photo above indicates the areas in the earliest (PLC-20) cabinet that re-wiring must be done.

## Early PLC-30 panel (2 of 2)

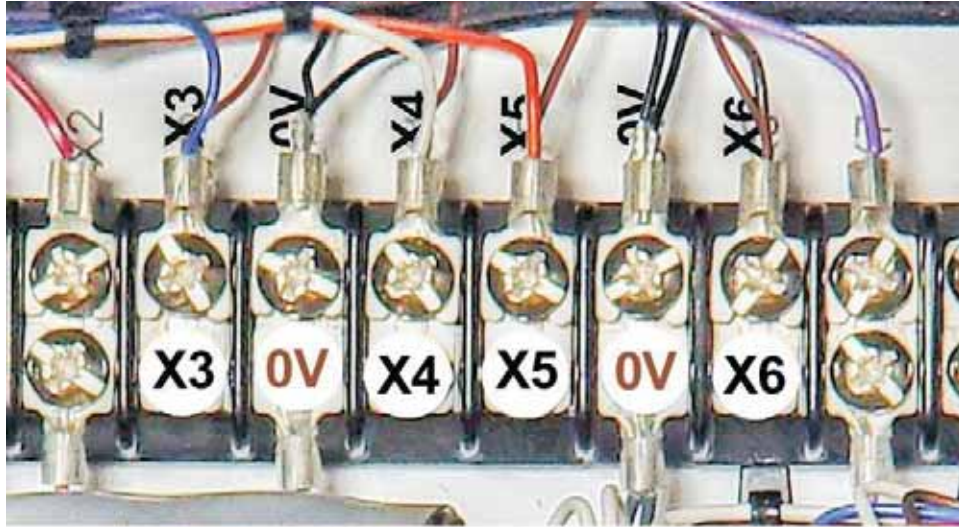

*On new sensors, black goes to X's, brown goes to 0V's*

The picture above shows the original sensor wires connected at the top terminal strip. The black wires from the old sensors get replaced with brown, and the brown wires get replaced with black. The extra blue wires are all connected to the 24V terminal.

- “Home” sensor black wire goes to X3; brown wire to 0V
- “Slow” sensor black wire goes to X4; brown wire to 0V
- “EoB/InPlace” sensor black wire goes to X5; brown wire to 0V
- “Eject” sensor black wire goes to X6; brown wire to 0V

*NOTE: The brown and black wires are reversed: new BROWN wires are on 0V; new BLACK wires are on the X-numbers.*

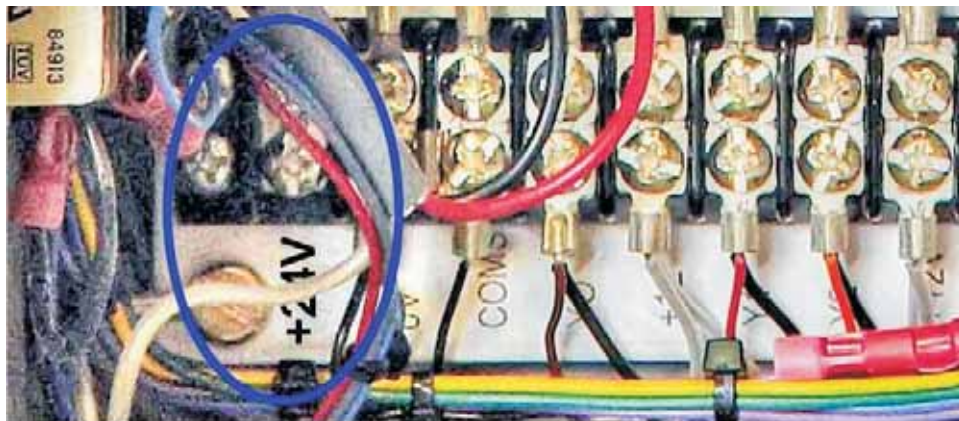

*All four blue wires must be connected to +24V terminal*

The picture above shows the “+24V” terminal. Connect blue wires from all sensors here.